

# Multinail Advance Rod Tie Down Plate

This Australian-manufactured bracket solution is specially designed and tested to connect upper floor tie-down threaded rods to timber beams.

## Benefits of Rod Tie Down Plate

The Rod Tie Down Plate is an Australian-manufactured bracket solution, specially designed to connect threaded rods to timber beams.

- Avoids the need to drill through the entire depth of timber beams
- Eliminates the need to notch out the bottom of timber beams to conceal nuts and washers
- Quick and easy to install

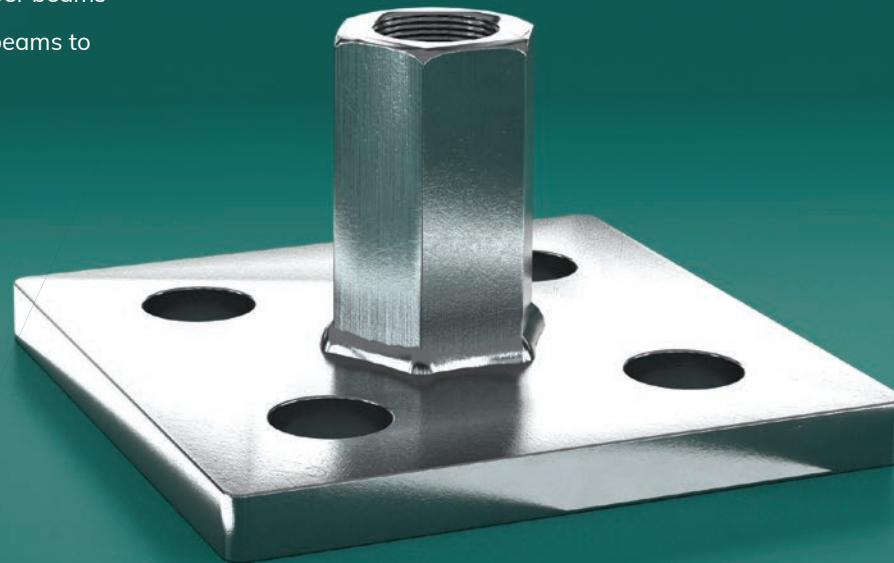

## About Multinail

Multinail is an Australian family-owned business established for over 40 years with all its products engineered, tested and manufactured at our industry-leading facility in Queensland, Australia.

The company specialises in the provision of quality metal connectors, software and engineering services to our partner network of licensed timber fabricators. Together, we offer an industry-wide service supplying prefabricated structural systems designed and engineered for optimising the efficiency and quality of timber construction.

## About Multinail Advance

Multinail Advance is an exciting addition to the Multinail Brand. Our core focus is to introduce Multinail's extensive range of products and services to new markets while innovating and developing solutions tailored to both existing and emerging sectors.

Our primary focus includes multi-residential projects, mid-rise buildings, and mass timber construction.

Multinail Advance is committed to enhancing the competitive edge of our fabricators by expanding timber construction into new markets and contributing to the growth of the Australian timber industry.



## Testing

Each Multinail Advance product undergoes rigorous testing to ensure its suitability and compliance with Australian engineering codes and standards.

Specifically, the Rod Tie Down Plate has undergone extensive in-house testing using glulam samples sourced from Australian suppliers that feature locally grown timber species. The primary objective of this testing was to validate the tie-down capacity of a pair of Rod Tie Down Plates and Multinail Advance Pan Head Screws' interactions with each structural components.

The test results showed that Rod Tie Down Plate can be an alternative tie-down method AS1684.2 and AS1684.3 Table 9.20 where there is M12 bolt specified for a beam or lintel.. Furthermore, it found no negative impact on the wall bottom plate and flooring panel during the test, due to partial threaded screw design for the Rod Tie Down Plate.



# Applications

The Rod Tie Down Plate is designed for the application of transferring the wind uplifting force through a glulam beam. It solves the issue of drilling through a deep glulam beam on site by simply attaching a pair of Rod Tie Down Plates above and below the glulam beam with Multinail Advance Pan Head Screws.



Figure 1



Figure 2



Figure 3

No more drilling  
through deep glulam beams!



Figure 4

# Design Uplift Capacity

Table 1 gives the design uplift capacities of Multinail Advance Rod Tie Down Plates. These capacities are for use as an alternative tie-down method when used with AS1684.2 and AS1684.3 Table 9.20 with M12 bolts to a beam/lintel.

**Table 1:** Design Uplift Capacities in kN (values extracted from AS1684.2 & AS1684.3)

Beam/lintel tie-down connection type	JD4	JD5	JD6
Table 9.20 (c) M12 bolt			
Table 9.20 (d) M12 bolt	20	16	12
Table 9.20 (e) M12 bolt			

**Important notes:**

If tie-down connections are designed under AS1720.1, ensure the design properties of timber beam/lintel are checked, as timber tension perpendicular to grain is the governing factor of this Rod Tie Down Plate connection system.

## Kit Contents

**Table 2:** Kit Content

Kit code	Rod Tie Down Plate	Screws	Installation Guide
RTGLT	4	25	1

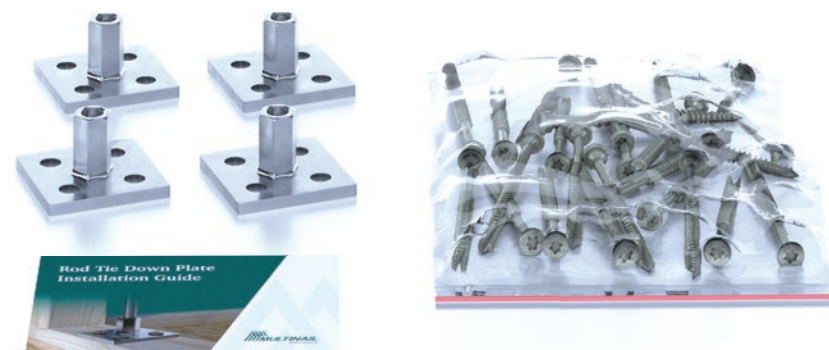

# Technical Specifications

## Rod Tie Down Plate

**Steel**  
G350 Steel, Zinc Plated, 6mm Thickness

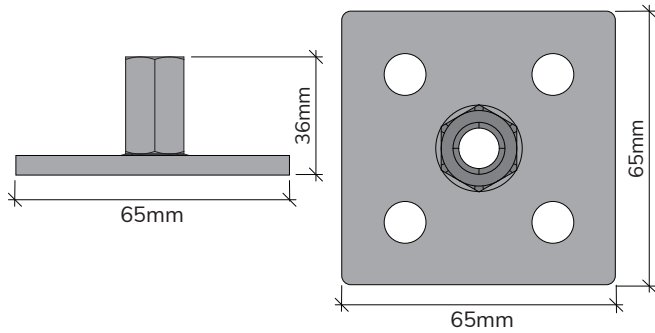

Product Code	Description H x W x L
RTGLT-P	65mm x 65mm x 36mm

## Screws

**Steel**  
Hardened carbon steel, Electrocoated

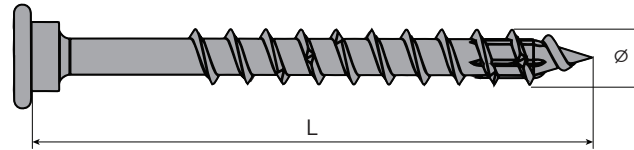

Product Code	Description Ø x L	Carton Qty
CH08150-25	Ø8x150mm	25



**Multinail Advance Pty. Ltd.**  
155 Burnside Road, Stapylton  
QLD 4207, Australia  
Phone: +61 (0)7 3297 3250  
Email: [advance@multinail.com](mailto:advance@multinail.com)  
[www.multinail.com.au](http://www.multinail.com.au)